

TAV.No 437
MOD.ECO 1000

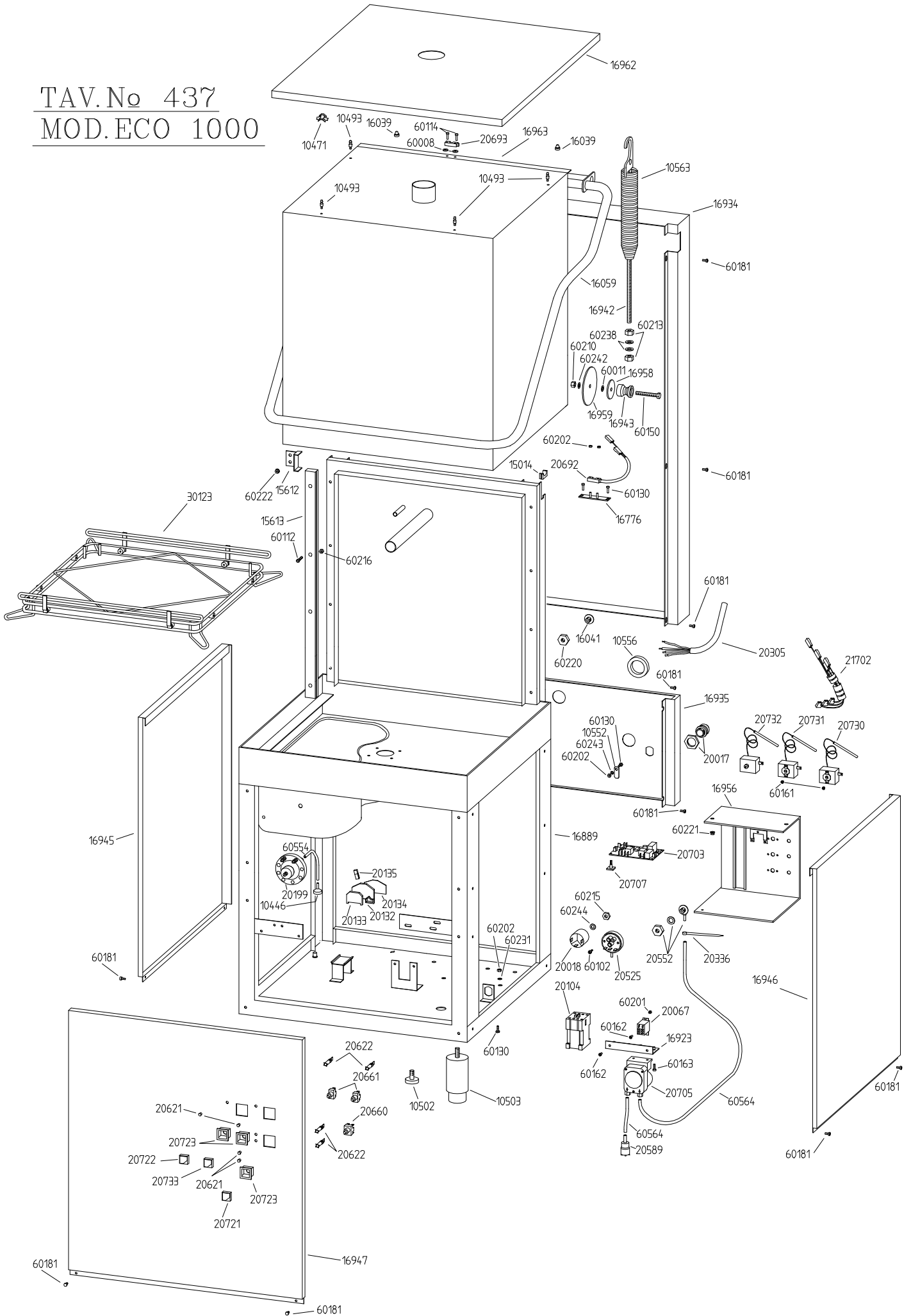

TAV. No 438 MOD. ECO 1000

